



Science.
Applied to Life.™



Custom Packaging Solutions

Food & Beverage Industry

www.3M.com.au



**At 3M, we didn't forget
that process efficiency
and flexibility keep you
at the forefront of your
industry.**

Between the farm and a meal on the table, making sure food is safe and fresh is a part of 3M. In a world where so many unexpected events can impact your results, 3M's Food & Beverage Industry Custom Packaging Solutions have you covered with dependable, high quality solutions and systems to meet your ever-changing requirements.

case sealers ▶

3M-Matic
Case Sealing Systems

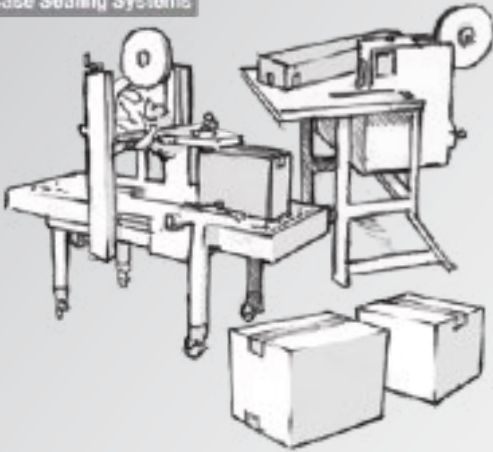

3M-Matic™ Case Sealers

From increasing capacity to meet seasonal demands or reengineering your packaging lines to accommodate new products, our rugged case sealers are designed to grow with you.



3M AccuGlide™ Taping Head Technology

3M™ AccuGlide™ Taping Heads are patented with curvilinear design that applies tape securely with low impact that helps protect even lightweight cartons and contents.

*throughput &
speed
consistency &
security*

packaging tapes, adhesives & dispensers ▶



Scotch



Scotch® Box Sealing Tapes

Consistency is a key to packaging tape. Delivering quality with tapes that keep production lines moving. From economical packaging tapes to specialty tapes that can be applied at temperatures of around 10°C for durable and secure closure at cold packing stations.

3M™ Hot Melt Adhesive Systems

Hot melt adhesives and self-contained applicators for manual operations, and bulk adhesives for higher volumes.

Scotch® Tape Dispensers

All Scotch® Manual Dispensers for box sealing tapes, filament tapes, film tapes, label protection tapes and pouch tapes are application designed to meet your needs.



bundling ▶

Scotch

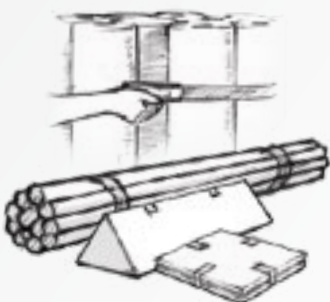

High Strength Filament Tapes

When you need a tape as strong as your reputation, you can rely on market-leading high strength filament tapes.

Strapping Tapes

For clean removal and high strength, polypropylene tapes will meet your needs. Great adhesion to vinyl, plastics, glass and metals that are printed or unprinted.

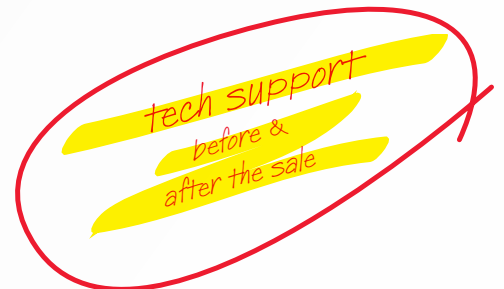

packing stations ▶



Scotch

*document attachment
label protection
patching*

ScotchPad™ Packaging Tape Pad

Make convenient closure repairs that save time and money and reduce the return of damaged containers.



3M™ Masking Tapes

With the introduction of the Masking Made Simple range, these five tapes are built on increasing levels of performance making it easier to choose the best tape for any job.



palletising ▶



*protection
control*



Scotch® Stretchable Tapes

Tape that gets stronger when stretched! Holds in place cartons and won't damage carton graphics, allow cartons to be scanned. Creates ventilated load for shipment of time and temperature sensitive goods.



Compliance & Certification

Protecting and preserving your product is critical. With recalls, food contamination, possible bioterrorism, and other supply chain issues, we all have to be increasingly concerned. 3M's compliance and certifications reduces your risks and gives you peace of mind. These include indirect food contact certifications for packaging tapes, electrical equipment compliance through to ethical sourcing audits and risk assessments.

*recycled
corrugated?
no problem!*

branding ▶



Scotch



3M™ Carry Handles

Convenience for your customer at purchase point or applied in your manufacturing process, 3M™ Carry Handles can differentiate your product. Gives on-shelf appeal and associate convenience with your brand.



Scotch® Multipack Tapes

Economical and sustainable alternative to shrink films, banding, boxes and bags. Bundle your brand into multipacks and value packs. Deliver promotional messages and barcoding.

packaging & labelling ▶

3M™ Packaging List Envelopes

A wide variety of choices for document control and protection. Convenient peel and stick documents to reclosable zipper closure envelopes.



Scotch® Tear Strips

High pull-rate success, easy opening of packages ranging from light weight envelopes to corrugated fibreboard.



3M™ Hang Tabs

Clear, durable, polyester tabs, easy to use with a pressure sensitive adhesive for easy instore repair or showcases of packaging.



3M™ Performance Labels

With more than 150,000 combinations of 3M adhesives, topcoats, facestocks and liners, 3M has the solutions you need to strengthen your competitive advantage.



shipping & warehousing ▶

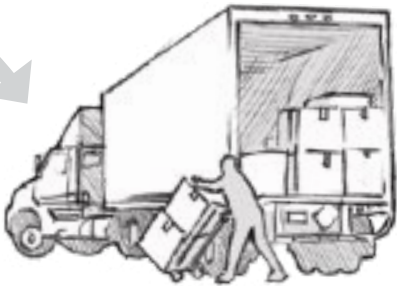

identification
security



Security Tapes

Tamper evident packaging tapes offer solutions to reduce 'shrinkage' and the cost of theft or attack.



Remote Sensing Tapes

3M™ High-Gain Reflective Sheeting makes it easy to design sensing and control systems based on simple, inexpensive photoelectric sensors.

3M™ Lane Marking Tapes

3M™ Vinyl and Hazard tapes come in vibrant colours and are easy to apply - faster than painting. They provide a cost-effective solution for marking lanes, hazards and safety areas in your facility.



- ▶ Product security
- ▶ Process efficiency
- ▶ Manufacturing flexibility
- ▶ Brand differentiation
- ▶ Retailer loyalty



Pack it. Close it. Move it. Sell it. Use it.



3M Australia Pty Ltd
Industrial Adhesives and Tapes Division
Bldg A, 1 Rivett Road
North Ryde NSW 2113

Phone 1300 363 848
Fax 1800 636 444
Email 3mindustrialau@mmm.com
Web www.3M.com.au

3M New Zealand Ltd
Industrial Adhesives and Tapes Division
94 Apollo Drive, Rosedale
Auckland 0632

Phone 0800 474 787
Email 3mzntb@mmm.com
Web www.3M.co.nz

3M, 3M-Matic, AccuGlide, ScotchPad and
Scotch are trademarks of 3M Company.
Please recycle. Printed in Australia.
© 3M 2016. All rights reserved.
AV011450036